

Indoor PM2.5 / PM10 / CO₂ / Temperature / Humidity 5-In-1 Detection Sensor

Model: WH45

Contents

1. Introduction	3
2. Unpacking	4
3. Features	5
4. Sensor Set Up	7
5. Sensor Installation	10
6. Wi-Fi Configure with Gateway	12
6.1 Pair with Gateway	12
6.2 Wi-Fi Connection for the Gateway	13
7. View Online Data on the web page (ecowitt.net) or WS View Plus/ Ecowitt App	13
8. Appendix	15
9. Sensor Calibration	18
10. Specification	20
11. Warranty Information	23



- *Please scan the QR code to read English manual and keep it for future reference
- *Bitte scannen Sie den QR-Code zu deutsche Anleitung lesen und aufbewahren für Zukunftsbezug
- *Si prega di scansionare il codice QR per leggi il manuale italiano e conservalo per Referenza futura

Instruction manuals

<https://www.ecowitt.com/support/download/97>

Help

Our product is continuously changing and improving, particularly online services and associated applications. To download the latest manual and additional help, please contact our technical support team:

support@ecowitt.com

support.eu@ecowitt.net (EU/UK)



MADE IN CHINA

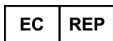

AC WORKS CONSULTING Srl
Via Vilfredo Pareto 125,47521
Casena(FC),ITALY

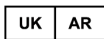

HUA TENG LIMITED
3 Glass Street, Hanley, Stoke On Trent,
ST1 2ET United Kingdom

1. Introduction

Thanks for your purchasing of this integrated multifunction indoor air quality monitoring sensor. It measures PM 2.5 / PM10 / CO2 / Temperature / Humidity. To ensure the best product performance, please read this manual and retain it for future reference.

2. Unpacking

Open your box and inspect that the contents are intact (nothing broken) and complete (nothing missing). Inside you should find the following:

QTY	Item Description
1	Particle Detection Sensor (PM2.5 / PM10 / /CO2 / Temperature / Humidity 5-In-1)
1	USB Cable
1	User Manual

Table: Package content

If any component is missing from the package, or broken, please contact our Customer Service department to resolve the issue.

3. Features

Particle Detection Sensor

- Measures indoor PM2.5, PM10, CO₂ concentration, Temperature and Humidity every 60 seconds when powered with USB or detecting every 10 minutes when powered with batteries only
- USB power connection for indoor use only
- CO2 value calibration function available on the device
- PM2.5 value Calibration function available when paired with the WiFi Gateway/GW1100/HP2551 /HP3500 /HP3501
- Long wireless range, up to 300 feet (100 meters) in open areas

When paired with a the WiFi Gateway/ GW1100 Wi-Fi Gateway:

- Monitor live sensor data on the Live Data page of the WS View Plus/ Ecowitt App (requires the gateway and your phone using the same Wi-Fi network)
- Displays current PM2.5 / PM10 concentration/AQI and 24H AQI and air quality level index on the Live Data page of the WS View Plus/ Ecowitt App
- Displays current CO₂ concentration and 24H average CO₂ concentration on the Live Data page of the WS View Plus/ Ecowitt App
- Displays temperature and humidity data where the sensor located
- Calibration function available for PM2.5 value

When paired with a Weather Station Console (HP2551/HP3500/HP3501):

- The PM2.5, PM10 and CO₂ data automatically scrolls displaying on the screen every 5 seconds

- Calibration function available for PM2.5 value

When uploaded to Ecowitt Weather Server:

- View current sensor data & history records & graph on the website
- Set and receive email alerts from the server when alarm condition set under your account.
- Remote monitoring with smart phone, laptop, or computer by visiting the website

Note: On the 48-hour self-test which takes place with maximum fan rotation and is therefore clearly perceptible. You can set the commissioning start time by removing the batteries and the USB connection to a point in time where the necessary fan noise does not interfere.

4. Sensor Set Up

1. Remove the battery door on the base of the air quality sensor as shown in Figure 1

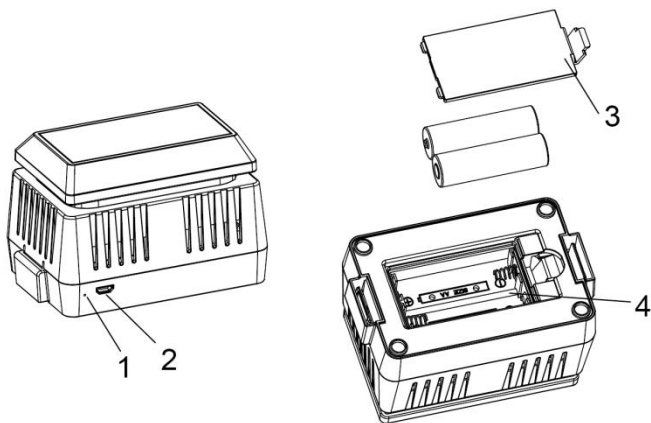

Figure 1

No	Description	No	Description
1	Red LED Indicator (RF transmission)	3	Battery Compartment Cover
2	AC Adapter USB Power Port	4	Battery Compartment

2. Insert two AA batteries and close the battery door.

Note: The batteries (not included) are mainly for backup purpose.

3. Connect the USB cable between the sensor and an AC adapter(not included).

Note: After inserting the batteries or connecting AC power, the sensor LED indicator will light for 3 seconds – flash once after 20s, and then flash once per 1 minute thereafter (10 minutes if only powered by batteries). Each time it flashes, the sensor is transmitting data.

5. Sensor Installation

Before install the sensor into its permanent location, you may go to Section 6 to configure with the gateway first. Once the sensor has been confirmed working correctly, then you can go back here.

Place the sensor on a horizontally surface. Note that the vents must be clear of any obstructions, and we recommend placement away from other electronic devices to prevent interference. Do not place on a metal table to prevent RF signal loss.

Note: This sensor is designed for indoor use only.

Wireless communication is susceptible to interference, distance, walls and metal barriers. We recommend the following best practices for trouble free wireless communication.

1. Electro-Magnetic Interference (EMI). Keep the console several feet away from computer monitors and TVs.

2. Radio Frequency Interference (RFI). If you have other devices using the same RF frequency and communication is intermittent, try turning off these other devices for troubleshooting purposes. You may need to relocate the transmitters or receivers to avoid intermittent communication.

3. Line of Sight Rating. This device is rated at 300feet line of sight (no interference, barriers or walls) but typically you will get 100feet maximum under most real-world installations, which include passing through barriers or walls.

4. Metal Barriers. Radio frequency will not pass through metal barriers such as aluminum siding. If you have metal siding, align the remote and console through a window to get a clear line of sight.

6. Wi-Fi Configure with Gateway

This Particle Detection Sensor doesn't has a display function and you need to view the data on weather server <https://www.ecowitt.net> or WS View Plus/ Ecowitt App after pairing this device with our the WiFi Gateway/GW1100 Wi-Fi Gateway or HP2551/HP3500/HP3501/WH0295 console (all sold separately).

6.1 Pair with Gateway

If the WiFi Gateway/GW1100 has been in operation, and you have never had any WH45 sensor setup before, just power up the sensor and the WiFi Gateway/GW1100 will pick sensor data automatically.

If a WH45 sensor has been hooked on the WiFi Gateway/GW1100 before, and you have a new sensor to replace the old one, just power off the old sensor and power on the new sensor, open the APP: WS View Plus/ Ecowitt App, tap the device and go to sensor ID page, locate the WH45 sensor, select "Register", then the gateway will erase the previous registered sensor and have the new sensor paired.

6.2 Wi-Fi Connection for the Gateway

For this part, please refer to the manual of the WiFi Gateway/GW1100 Wi-Fi gateway.

Any question, please contact the customer service.

7. View Online Data on the web page (ecowitt.net) or WS View Plus/ Ecowitt App

When the Wi-Fi configuration is done, you can view the live data of your sensor on the web page (ecowitt.net) or WS View Plus/ Ecowitt App.

Device List		Live Data		More	
GW1000B-WIFI38B4					
Indoor Temperature			Indoor Humidity		
30.1 °C			71 %		
Absolute Pressure			Relative Pressure		
992.3 hPa			992.3 hPa		
CO2 (bc)					
Temperature			Humidity		
32.5 °C			63 %		
PM2.5	Real-time AQI	24H AQI			
1.6 ug/m ³	7 Good	21 Good			
PM10	Real-time AQI	24H AQI			
2.3 ug/m ³	2 Good	6 Good			
CO2			24H CO2		
463 ppm			507 ppm		
GW1000B_V1.6.3					

Figure 2

Note:

The WH45 sensor data can be only viewed on the Live Data interface since it doesn't support uploads to weather underground.

If you choose to upload the data to our weather server: <https://www.ecowitt.net>, you can view the live data/history graph and download the records on the website. You can add a shortcut of the website on the home screen of your phone for quick access.

8. Appendix

Air Quality Index (AQI) for the PM_{2.5} Concentration (24hr)

AQI	Air Pollution Level	PM_{2.5} Concentration ug/m³
0 - 50	Good	0.0-12.0
51 -100	Moderate	12.1-35.4
101-150	Poor	35.5-55.4
151-200	Unhealthy	55.5-150.4
201-300	Severe	150.5-250.4
300+	Hazardous	250.5+

Air Quality Index (AQI) for the PM10 Concentration (24hr)

AQI	Air Pollution Level	PM2.5 Concentration ug/m3
0 - 50	Good	0-54
51 -100	Moderate	55-154
101-150	Poor	155-254
151-200	Unhealthy	255-354
201-300	Severe	355-424
300+	Hazardous	425+

Carbon Dioxide Levels and potential health problems are indicated below:

- 250-350 ppm: background (normal) outdoor air level
- 350-1,000 ppm: typical level found in occupied spaces with good air exchange

- 1,000-2,000 ppm: level associated with complaints of drowsiness and poor air
- 2,000-5,000 ppm: level associated with headaches, sleepiness, and stagnant, stale, stuffy air; poor concentration, loss of attention, increased heart rate and slight nausea may also be present.
- >5,000 ppm: This indicates unusual air conditions where high levels of other gases also could be present. Toxicity or oxygen deprivation could occur. This is the permissible exposure limit for daily workplace exposures.
- >40,000 ppm: This level is immediately harmful due to oxygen deprivation.

Reference link:

<https://ohsonline.com/Articles/2016/04/01/Carbon-Dioxide-Detection-and-Indoor-Air-Quality-Control.aspx?Page=2>

9. Sensor Calibration

CO₂: There is an easy way to find the CO₂ sensor is drifted or not: put the sensor in outdoor open air locations, away from any combustion exhausts, wait for 30 minutes, you should see the CO₂ reading is 420ppm +/-10. If it is far from this reading, you can wait for some more time, and test it during night to confirm. Once it is confirmed, you can open the back housing, and use a clipper pin to press the Calibrate button as below figure shows, leave it for 30s, and the reading will be shifted back to 420ppm.

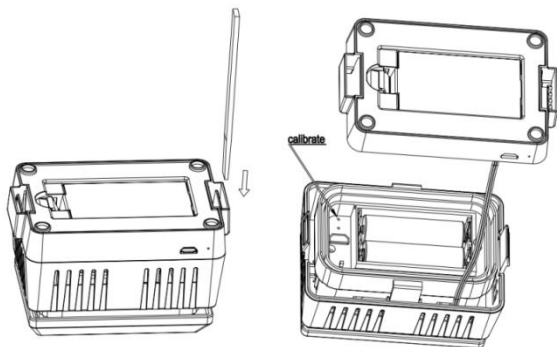

Figure 3

Note:

If you have a reliable source to calibrate the CO₂ data, you may calibrate the offset on the web page (ecowitt.net) or the WS View Plus/ Ecowitt App(for the WiFi Gateway/GW1100/WN1900 only), or the HP2551 /HP3500/HP3501 console. If the deviation is large, it's recommended to place the sensor in an outdoor ventilated place for 30 minutes before calibrating.

PM_{2.5}: It is not possible to calibrate on the sensor side, and you can calibrate through the web page (ecowitt.net) or WS View Plus/ Ecowitt App when paired with the WiFi Gateway/GW1100 or on the console when paired with HP 2551/HP3500/HP3501, which saves the offset value on the gateway side before sending data to www.ecowitt.net server. However if PM_{2.5} data is persistently low, it can be that there is a spider net going inside the sensor. So please clean the sensor from time to time to see if there is any sign of spider penetration.

Note: If the battery level is lower than 4 bars, calibration is prohibited. When the led light on the sensor is steady for 3 seconds, it indicates that calibration is prohibited.

10. Specification

Measurement	Range	Accuracy	Resolution
PM 2.5	0~999ug/m3	0-100ug/m3, ±10ug/m3 100- 1000ug/m3, ±10%	1ug/m3
PM 10	0~999ug/m3	0-100ug/m3, ±25ug/m3 100- 1000ug/m3, ±25%	1ug/m3
CO ₂	0- 40000ppm	400- 10000ppm ±(30ppm ±3%)	1ppm
Temperature	-40°C – 60°C (-40°F - 140°F)	± 1°C, or ± 2°F	0.1°C, or 0.1°F
Humidity	1%~99%	± 5%	1%

Transmission distance in open field: 100m(300 feet)

Frequency: 915/868/433MHz (915MHz for North America, 868MHz for Europe, 433MHz for other areas)

Sensor reporting interval: 1 minute (10 minutes when only powered by batteries)

Power consumption

- Particle Detection Sensor: AC power (5V 1A) - Not included
- 2 x AA 1.5V Batteries for back up - Not included

Note:

One set alkaline battery could only last for three days, when sensor powered by battery only.

Note:

If you have a WH41 or WH43 PM2.5 sensor, the reading of PM2.5 may be different due to different sensor type used.

Note:

This device is mainly used to detect the particle concentration in air. The accuracy for temperature and humidity reading may vary due to different environment:

When the sensor is placed at unventilated environment, the temperature reading may be 2 degrees higher in worst case.

When the sensor is placed at ventilated environment, the temperature and humidity reading may be lower than the actual reading.

11. Warranty Information

We disclaim any responsibility for any technical error or printing error, or the consequences thereof.

All trademarks and patents are recognized.

We provide a 1-year limited warranty on this product against manufacturing defects, or defects in materials and workmanship.

This limited warranty begins on the original date of purchase, is valid only on products purchased, and only to the original purchaser of this product. To receive warranty service, the purchaser must contact us for problem determination and service procedures.

This limited warranty covers only actual defects within the product itself and does not cover the cost of installation or removal from a fixed installation, normal setup or adjustments, or claims based on misrepresentation by the seller, or performance variations resulting from installation-related circumstances.